



Performance

- Gradually reduces wheat to obtain an extraction rate equivalent to an industrial mill

Equivalence

- A patented mill diagram specifically designed to obtain precise information on the behavior of the wheat being evaluated
- LabMill produces flour that is representative of the wheat being milled

Compliance with the ISO 27971 standard

- Compliant with the ISO 27971 standard (with factory settings)

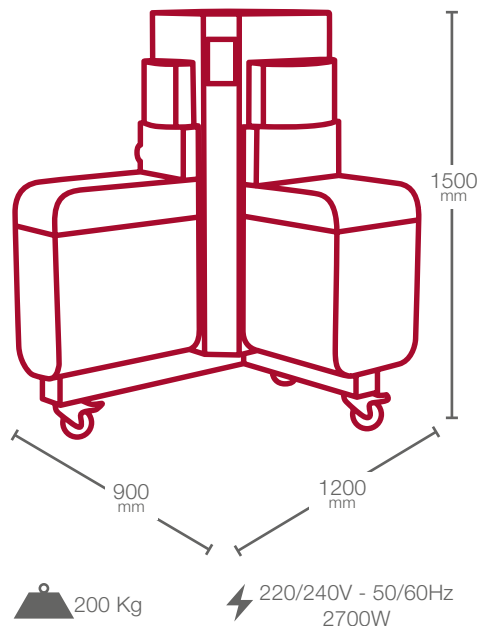

Test time : **20 minutes**
Operator time : **12 minutes**

Milling Value and behavior of wheat during milling

Milling Quality is associated with the extraction rate, in other words, with the maximum amount of flour of a certain quality obtained, often defined by ash content. It is important as even a low yield gap has significant economic consequences.

It is also useful to know precisely the behavior of wheat during milling. Actually, depending on the characteristics of the grain, most flour is made during the breaking or reduction stage. The industrial mill diagram should therefore be perfectly suited to the type of grain used.



Flour value of use

Laboratory milling is a key element of wheat quality control as it heavily determines the technological characteristics of the flour produced. A high extraction rate only makes sense if it is associated with a flour quality in compliance with its industrial use. Milling quality is associated with ash content (which represents its purity), but also with its technological characteristics (measured by rheological analyses or bread-making tests).

LabMill makes flour that is qualitatively representative of industrial flour.

LabMill is used to anticipate, in the laboratory, the behavior of wheat in the industrial mill, and to evaluate its extraction potential and the quality of the flour produced.



LabMill in the grain industry

For Wheat Breeders

Use with as little as 50g samples of wheat.

For Millers

Choice of wheat, making blends, optimization of tempering, adaptation of settings...

For Ingredient Specialists

Milling up to 3.5kg in one pass, for bread-making tests.

For Control Labs and Research Institutes

Carrying out of repeatable and reproducible milling representative of the quality of wheat implemented.

For Universities, Schools...

Wheat milling education with a tool representative of industrial practices (grooved cylinders, smooth cylinders, sifting...).



A unique milling diagram

Patented*, LabMill's innovative milling diagram is comprised of 5 consecutive steps:

- 2 breaking steps to make flour, fine middlings, coarse middlings, and bran.
- 1 sizing step to reduce coarse middlings to flour, fine middlings, and fine bran.
- 2 or 3 reduction steps to reduce fine middlings to flour.

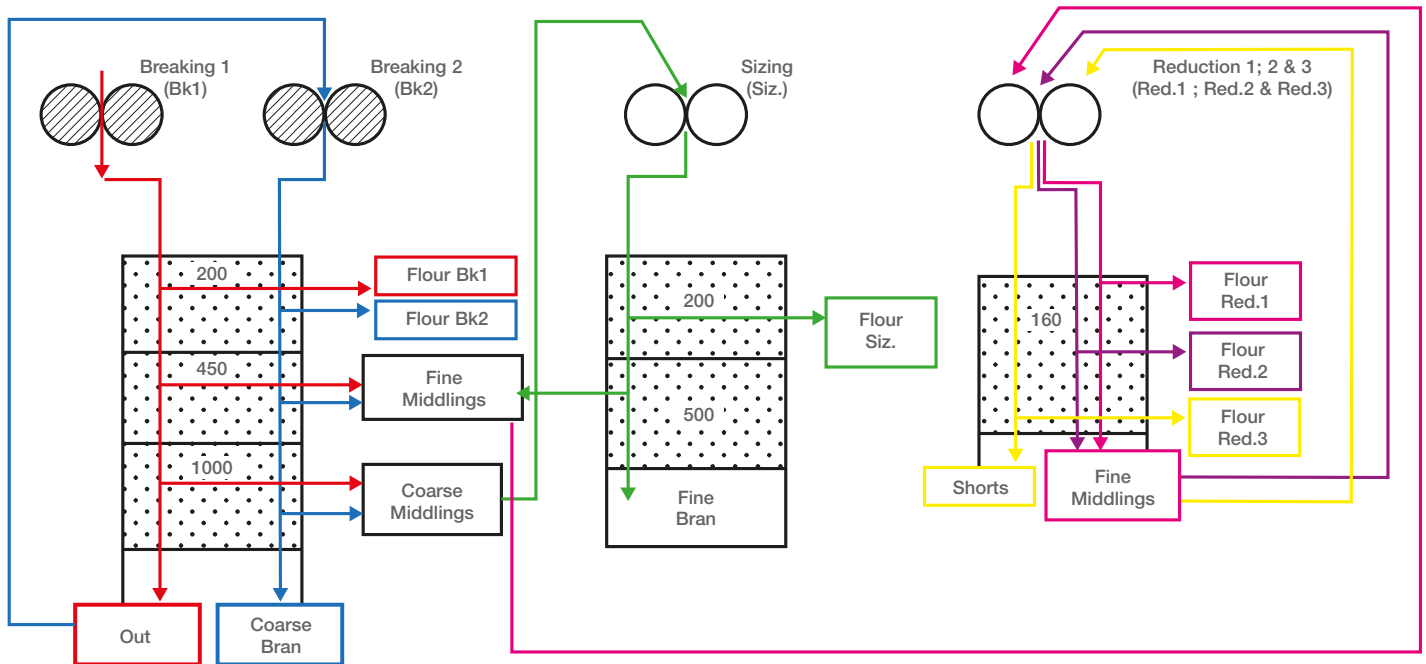

A very precise feed system

Equipped with a precise scale, LabMill's feed system releases a constant flow of grain, adapted to every type of wheat.



Adjustable cylinders

The grinding unit automatically switches from a first-breaking configuration to a second-breaking configuration.

Reduction and converting are carried out on the same pair of smooth cylinders, a bypass selects the corresponding sieve.

The cylinders are mounted on eccentric bearings, which allows for special adjustments.



A complete and compact mill

All access is via the top and front of the device, which allows you to carry out all analysis and maintenance operations in optimal ergonomic conditions.

LabMill was developed within the Milling Quality Consortium (AFSA, Arvalis-institut du végétal, ANMF, Danone Vitapole, INRA, IRTAC, Ulice, CHOPIN Technologies).

*Patent FR N° 0905572 | US N°9 067 210



High extraction rate

The extraction rate obtained on the LabMill is particularly high compared to its short milling diagram.

It is between 66% and 81%, with an average of 77% for hard wheat and 75% for soft wheat.

In comparison with a reference mill, more than 87% of extraction rates are correctly predicted using the LabMill in a confidence interval of +/-1%.

This allows you to directly identify the lots of wheat most conducive to a high extraction rate in industrial milling.

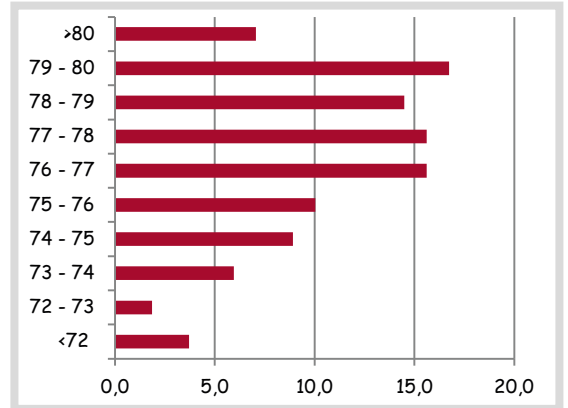

Excellent flour quality

LabMill is specifically designed to reproduce industrial milling conditions and to obtain a representative flour quality.

Flour purity

Flour purity is traditionally measured by ash content. In LabMill's case, it is between 0.50% and 0.63%/ms, which corresponds to a 55 ash flour commonly used in bread-making.

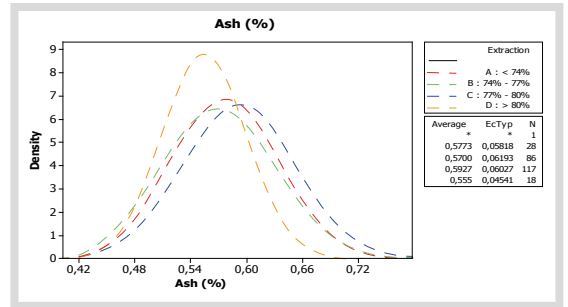

Technological quality

Flour purity, however, does not shed much light on its technological quality. A comparison study between the results obtained on the Alveograph following wheat milling under ISO 27971 demonstrates that the rheological quality of flour made with LabMill is equivalent to flour made by industrial milling.

Numerous adaptation possibilities

LabMill is delivered preset and with a set of sieves allowing for use according to the requirements of regulation ISO 27971. An experienced user, however, has the possibility to create their own milling conditions by:

- Adjusting the gap of the grooved cylinders (Bk1 and Bk2)
- Adjusting the gap of the smooth cylinders (breaking and converting)
- Modifying the sifting time
- Changing feed speed of different products.

